



# A simulated bushfire test report

Test standard: Clauses 14 and 16 of AS 1530.8.1:2018

Test sponsor: Breezway® Australia Pty Ltd

Products: Breezway® Altair® Louvre in an Easyscreen™ Window System

Breezway® Altair® IGLU® Louvre in an Easyscreen™ Window System

Bushfire attack level (BAL) exposure: 40 kW/m<sup>2</sup> Crib class: AA



Job number: FRT200407

Test date: 13 April 2021 Revision: R1.0

Warringtonfire: accredited for compliance with ISO/IEC 17025 – Testing



## Quality management

Revision	Date	Information about the report			
R1.0	19 May 2021	Description	Initial issue		
		Name Signature	Prepared by	Reviewed by	Authorised by
			Masis Altun	Mandeep Kamal	Mandeep Kamal
					

## Executive summary

This report documents the findings of a simulated bushfire attack – radiant heat and small flaming sources test on elements of construction for buildings undertaken on 13 April 2021 in accordance with clauses 14 and 16 of AS 1530.8.1:2018.

Warringtonfire performed the test at the request of Breezway® Australia Pty Ltd.

Table 1 provides details of the test assembly, and Table 2 provides a summary of the test specimen. A summary of the results is provided in Table 3.

**Table 1 Test assembly**

Item	Detail	
Separating element	90 x 45 timber stud frame clad with regular 10 mm thick regular plasterboard on the unexposed side and 9 mm thick fibre cement board on the exposed side. The eave was clad using 6 mm thick fibre cement board.	
Combination window system	Breezway® Altair® Louvre in an Easyscreen™ Window System Breezway® Altair® IGLU® Louvre in an Easyscreen™ Window System	
Nominal separating element size	Width	3000 mm
	Height	3000 mm
	Thickness	109 mm
Nominal window system size	Width	2453 mm
	Height	2514 mm
	Thickness	157 mm

**Table 2 Test specimen**

Item	Detail
Test specimen	<p>The tested system was nominally 2453 mm wide x 2514 mm high x 157 mm thick and consisted of the Breezway® Australia Pty Ltd Altair® louvre in an Easyscreen™ window system and the Altair® IGLU® louvre in an Easyscreen™ window system. Both systems incorporated the Invisi-Gard screen on the exposed side.</p> <p>The wall consisted of a 90 x 45 timber stud frame that was clad with 9 mm thick fibre cement board on the exposed side and 10 mm thick regular plasterboard on the unexposed side. The eave was clad using 6 mm thick fibre cement board.</p>

**Table 3 Test results**

Performance criteria		Time to failure (min.)	Position of failure
Formation of through-gaps greater than 3 mm		No failure	-
Sustained flaming for 10 s on the non-fire side		No failure	-
Flaming on the fire-exposed side at the end of the 60 minute test period		No failure	-
Radiant heat flux 365 mm from the non-fire side exceeding 15 kW/m <sup>2</sup>		No failure	-
Mean and maximum temperature rises greater than 140 K and 180 K		Not applicable	-
Radiant heat flux 250 mm from the specimen, greater than 3 kW/m <sup>2</sup> between 20 min and 60 min		No failure	-
Mean and maximum temperature of internal faces exceeding 250 °C and 300 °C respectively between 20 min and 60 min after commencement of test		No failure	-
<b>Crib class</b>	Type AA	<b>Peak heat flux</b>	40 kW/m <sup>2</sup>
<b>Test result</b>		BAL— AA40	

## Contents

1.	Introduction	6
2.	Test specimen	6
2.1	Schedule of components	6
2.2	Installation details	9
3.	Test procedure	10
4.	Test measurements and results	11
5.	Application of test results	12
5.1	Test limitations	12
5.2	Variations from the tested specimen	12
5.3	Uncertainty of measurements	12
Appendix A	Drawings of test assembly	13
Appendix B	Test observations	19
Appendix C	Direct field of application	20
Appendix D	Instrumentation locations	21
Appendix E	Test data	25
Appendix F	Photographs	30

## 1. Introduction

This report documents the findings of a simulated bushfire attack – radiant heat and small flaming sources test on elements of construction for buildings undertaken on 13 April 2021 in accordance with clauses 14 and 16 of AS 1530.8.1:2018.

Warringtonfire performed the test at the request of the test sponsor listed in Table 4.

**Table 4 Test sponsor details**

Test sponsor	Address
Breezway® Australia Pty Ltd	35 Cambridge Street Coorparoo QLD 4151 Australia

## 2. Test specimen

### 2.1 Schedule of components

Table 5 describes the test specimen and lists the schedule of components. These were provided by the test sponsor and surveyed by Warringtonfire.

All measurements were done by Warringtonfire – unless indicated otherwise.

Detailed drawings of the test specimen are provided in Appendix A.

**Table 5 Schedule of components**

Item	Description	
<b>Separating element</b>		
1.	Item name	Framing
	Product name	90 × 45 MGP10 Radiata pine
	Density	489 kg/m <sup>3</sup> (measured)
	Location	Located around the perimeter of the specimen and the wall system. Noggings were located at nominal 1000 mm centres to the sides of the specimen. Jack studs were located at nominal 300 mm centres above and below the specimen.
2.	Item name	Unexposed cladding
	Product name	10 mm thick regular plasterboard
	Density	566 kg/m <sup>3</sup> (measured)
	Location	Fixed directly to the timber framing on the unexposed face of the specimen.
	Fixings	6g × 32 mm bugle head plasterboard screws at approximately 300 mm centres through the timber framing.
3.	Item name	Exposed cladding
	Product name	9 mm thick CSR Cemintel® CeminSeal® Wallboard fibre cement board
	Density	1625 kg/m <sup>3</sup> (nominal)
	Location	Fixed directly to the timber framing on the exposed face of the specimen.
	fixings	6g × 32 mm bugle head plasterboard screws at approximately 200 mm centres through the timber framing.
4.	Item name	Eaves sheet lining
	Product name	6 mm thick CSR Cemintel® CeminSeal® Wallboard fibre cement board
	Density	1625 kg/m <sup>3</sup> (nominal)
	Location	Fixed directly to the exposed side of the timber framing along the eaves.

Item	Description	
	fixings	6g x 32 mm bugle head plasterboard screws at approximately 200 mm centres through the timber framing.
5.	Item name	Sill cladding
	Product name	13 mm thick GYPROCK® Fyrchek™ plasterboard
	Density	833 kg/m <sup>3</sup> (nominal)
	Location	Fixed directly to the timber framing at the sill
	Fixing	6g x 32 mm bugle head plasterboard screws at approximately 200 mm centres through the timber framing.
6.	Item name	Sill cladding
	Product name	6 mm thick CSR Cemintel® CeminSeal® Wallboard fibre cement board
	Density	1625 kg/m <sup>3</sup> (nominal)
	Location	Above the plasterboard (item 5) and fixed through to the timber framing at the sill.
	Fixing	6g x 32 mm bugle head plasterboard screws at approximately 200 mm centres through to the timber framing.
Note	References to the specimen are from the unexposed face unless stated. North references are to the right and south references are to the left.	
System	Breezway® Altair® Louvre in an Easyscreen™ Window System Breezway® Altair® IGLU® Louvre in an Easyscreen™ Window System	
<b>Glazing</b>		
Altair® 152 mm louvre window		
7.	Material	6 mm Grade A clear toughened glass
	Size	Overall pane size was nominal 152 mm high x 1127 mm wide Visible pane size was nominal 152 mm high x 1085 mm wide
Altair® IGLU® louvre window		
8.	Material	5 mm low emissivity glass / 12 mm argon gas space / 5 mm low emissivity glass (5LE/12AR/5LE IGU) with an overall thickness of 22 mm.
	Size	Overall pane size was nominal 140 mm high x 1127 mm wide Visible pane size was nominal 140 mm high x 1085 mm wide
<b>Framing</b>		
Overall Window Frame		
9.	Size	Overall frame dimensions of 2514 mm high x 2453 mm wide
	Material	Extruded Aluminium
Altair® 152 mm louvre window		
10.	Size	Overall frame dimensions of 2471 mm high x 1173 mm wide
	Material	Extruded Aluminium
a.	Head	Head frame
		Overall size: 131 mm deep x 95 mm high, various thicknesses, 1.2 mm nominal
b.	Sill	Sill frame
		Overall size: 131 mm deep x 83 mm high, various thicknesses, 1.2 mm nominal
c.	Jamb	Jamb

Item	Description	
		Overall size: 131 mm deep x 32 mm wide, various thicknesses, 1.2 mm nominal
d.	Coupler	Frame coupler
		Overall size: 131 mm deep x 66 mm wide, various thicknesses, 1.4 mm nominal
Altair® IGLU® louvre window		
11.	Size	Overall frame dimensions of 2476 mm high x 1176 mm wide
	Material	Extruded Aluminium
a.	Jamb	Jamb
		Overall size: 131 mm deep x 32 mm wide, various thicknesses, 1.2 mm nominal
b.	Head	Head frame
		Overall size: 131 mm deep x 68 mm high, various thicknesses, 1.4 mm nominal
c.	Sill	Sill frame
		Overall size: 131 mm deep x 83 mm high, various thicknesses, 1.4 mm nominal
		Overall size: 53 mm deep x 48 mm high, various thicknesses, 1.5 mm nominal
<b>Hardware</b>		
Altair® 152 mm louvre window		
12.	Item name	Altair® gallery handle
	Material	Polypropylene (PP)
	Location	On the unexposed side of the south side jamb
Altair® IGLU® louvre window		
13.	Item name	Altair® gallery handle
	Material	Polypropylene (PP)
	Location	On the unexposed side of the south side jamb
<b>Gaskets, seals and miscellaneous components</b>		
Altair® 152 mm louvre window		
14.	Name	Pine reveal
	Material	19 mm high x 116 mm deep radiata pine
	Location	Around the external perimeter of the outer frame.
15.	Name	Altair® gallery
	Material	Polypropylene (PP) and Polyoxymethylene (POM)
	Location	At the jambs on either side of each piece of glazing.
16.	Name	Weatherseal
	Material	Santoprene (TPV) / Polypropylene (PP) co extrusion
	Location	Head and sill inserts (jamb to jamb)
17.	Name	Invisi-Gard security screen
	Material	#316 stainless-steel
	Overall size	2424 mm high x 2403 mm wide



Item	Description	
	Head and sill size	10 mm deep × 15 mm high
	Jamb size	10 mm deep × 15 mm wide
	Mesh size	2.0 mm × 2.0 mm mesh size × 1.0 mm thick
	Location	On the exposed side of the louvre window system
Altair® IGLU® louvre window		
18.	Name	Pine reveal
	Material	19 mm high × 116 mm deep radiata pine
	Location	Around the external perimeter of the outer frame.
19.	Name	Altair® gallery
	Material	Polypropylene (PP) and Polyoxymethylene (POM)
	Location	At the jambs on either side of each piece of louvre glazing.
20.	Name	Weather seal
	Material	Acrylonitrile Styrene (ASA) / Arprene
	Location	On the top and bottom of each piece of louvre glazing, and at the head and sill inserts (jamb to jamb)
21.	Name	Invisi-Gard security screen
	Material	#316 stainless-steel
	Overall size	2424 mm high × 2403 mm wide
	Head and sill size	10 mm deep × 15 mm high
	Jamb size	10 mm deep × 15 mm wide
	Mesh size	2.0 mm × 2.0 mm mesh size × 1.0 mm thick
	Location	On the exposed side of the louvre window system

## 2.2 Installation details

Table 6 lists the installation details for the test specimen.

**Table 6 Installation details**

Item	Detail
Start date for construction of separating element	9 April 2021
Separating element constructed by	Representatives of Warringtonfire
Glazing system assembled by	Representatives of Warringtonfire
Glazing system installed into the separating element by	Representatives of the test sponsor
Symmetry	<p>Asymmetrical due to:</p> <ul style="list-style-type: none"> <li>The security screen installed on the exposed side of the window systems.</li> <li>The exposed side of the wall system clad with 9 mm thick fibre cement board and the unexposed side lined with 10 mm thick regular plasterboard.</li> </ul> <p>It was confirmed that the system was exposed to heat from the side that would normally face the outside of the building.</p>

### 3. Test procedure

Table 7 details the test procedure for this simulated bushfire test.

**Table 7 Test procedure**

Item	Detail	
Statement of compliance	The test was performed in accordance with the requirements of clauses 14 and 16 of AS 1530.8.1:2018 for an external construction.	
Variations	The specimen configuration of 2453 mm wide x 2514 mm high varied from the standard configuration of 2400 mm wide x 2400 mm high as specified in AS 1530.8.1:2018, hence the direct field of application has been reduced. Additional instrumentation was included for assessment purposes only.	
Pre-test conditioning	The construction and installation of the test specimen was completed on 12 April 2021. The test specimen was subjected to normal laboratory temperatures and conditions between the completion of construction of the test specimen and the start of the test.	
Sampling / specimen selection	The laboratory was not involved in sampling or selecting the test specimen for the simulated bushfire test. The results obtained during the test only apply to the test samples as received and tested by Warringtonfire.	
Ambient laboratory temperature	Start of the test	25 °C
	Minimum temperature	23 °C
	Maximum temperature	39 °C
Test duration	The test was stopped after 60 minutes in accordance with the procedures in AS 1530.8.1:2018.	
Instrumentation and equipment	<p>The instrumentation was provided in accordance with AS 1530.8.1:2018 as follows:</p> <ul style="list-style-type: none"> <li>The unexposed side specimen temperatures were measured by Type K thermocouples with wire diameters less than 0.5 mm soldered to 12 mm diameter x 0.2 mm thick copper discs covered by 30 mm x 30 mm x 2.0 mm thick inorganic insulating pads.</li> <li>The thermocouple positions are shown in Table 10 and in Figure 4 in Appendix D.</li> <li>A Ø3 mm gap gauge was available during the test to assess the performance of the specimen under the criteria of integrity.</li> <li>Deflection measurements were taken from wire drawn encoders at the positions shown in Table 11 and in Figure 4 in Appendix D.</li> <li>A pilot ignition source was available to assess any areas of the specimen producing significant quantities of volatiles.</li> <li>The crib was conditioned for at least 24 hours in a conditioning oven and removed 1 hour before the start of the test.</li> <li>The crib was weighed to confirm that it was within the 0.152 ± 0.03 kg mass required by the standard. The crib was lit over a 2 minute period – 20 seconds on the upper 0.10 m x 0.10 m face. 20 seconds on each of the 0.54 m x 0.10 m faces, and a further 20 seconds on the upper 0.10 m x 0.10 m face – using an oxyacetylene torch with Type 551 size 8 x 10 heating tip.</li> <li>Radiant heat flux measurements – to determine the irradiance transmitted from the exposed face of the specimen – were taken using Medtherm heat flux gauges.</li> <li>During calibration, a heat flux gauge was centrally located next to the specimen at a distance equal to the leading surface of the specimen. A second heat flux gauge was located close to the vertical centre of the specimen – at the leading edge, in the south wall section at a height of 2265 mm from the floor.</li> </ul>	

Item	Detail
	<ul style="list-style-type: none"> <li>During the test, the heat flux gauge that was in the south wall section at a height of 2265 mm from the floor remained in place, using values found during an ancillary pre-test calibration to determine the heat flux at the leading edge of the glazing.</li> <li>During the test, second and third heat flux gauges were centrally located next to the glazed elements of the specimen – at a distance of 365 mm behind the unexposed face of the specimen and 250 mm in front of the exposed face of the specimen. This was to determine the transmission of radiative flux through the specimen during the test, and to determine the radiant heat flux 250 mm from the exposed side of the specimen during the 20 to 60 minutes periods of the test.</li> <li>The heat flux gauge positions are shown in Figure 7 in Appendix E.</li> </ul>

## 4. Test measurements and results

Table 8 summarises the results the specimen achieved against the performance criteria listed in clauses 14 and 16 of AS 1530.8.1:2018.

Appendix E includes details of the measurements taken during the test.

Table 9 in Appendix B includes observations of any significant behaviour of the specimen and details of the occurrence of the various performance criteria specified in AS 1530.8.1:2018.

Photographs of the specimen are included in E.4.

**Table 8 Test results**

Performance criteria	Time to failure (min.)	Position of failure
Formation of through-gaps greater than 3 mm	No failure	-
Sustained flaming for 10 s on the non-fire side	No failure	-
Flaming on the fire-exposed side at the end of the 60 minute test period	No failure	-
Radiant heat flux 365 mm from the non-fire side exceeding 15 kW/m <sup>2</sup>	No failure	-
Mean and maximum temperature rises greater than 140 K and 180 K	Not applicable	-
Radiant heat flux 250 mm from the specimen, greater than 3 kW/m <sup>2</sup> between 20 min and 60 min	No failure	-
Mean and maximum temperature of internal faces exceeding 250 °C and 300 °C respectively between 20 min and 60 min after commencement of test	No failure	-
<b>Crib class</b>	Type AA	<b>Peak heat flux</b>
		40 kW/m <sup>2</sup>
<b>Test result</b>	BAL— AA40	

## 5. Application of test results

### 5.1 Test limitations

The results of these fire tests may be used to directly assess fire hazard, but it should be recognised that a single test method will not provide a full assessment of fire hazard under all fire conditions.

These results only relate to the behaviour of the specimen of the element of construction under the particular conditions of the test. They are not intended to be the sole criteria for assessing the potential fire performance of the element in use, and they do not necessarily reflect the actual behaviour in fires.

### 5.2 Variations from the tested specimen

This report details methods of construction, the test conditions and the results obtained when the specific element of construction described here was tested following the procedure outlined in AS 1530.8.1:2018. Any significant variation with respect to size, construction details, loads, stresses, edge or end conditions, other than that allowed under the field of direct application in the relevant test method, is not covered by this report.

It is recommended that any proposed variation to the tested configuration – other than as permitted under the field of direct application specified in Appendix C – should be referred to the test sponsor. They should then obtain appropriate documentary evidence of compliance from Warringtonfire or another accredited testing authority.

### 5.3 Uncertainty of measurements

Because of the nature of fire resistance testing and the consequent difficulty in quantifying the uncertainty of measurement of fire resistance, it is not possible to provide a stated degree of accuracy for the result.

## Appendix A Drawings of test assembly

The drawings of the test assembly in Figure 3 to Figure 6 were provided by the test sponsor and annotated by Warringtonfire where the leaders in the drawings represent the items listed in section 2.1.

All measurements – unless indicated – are in millimetres.

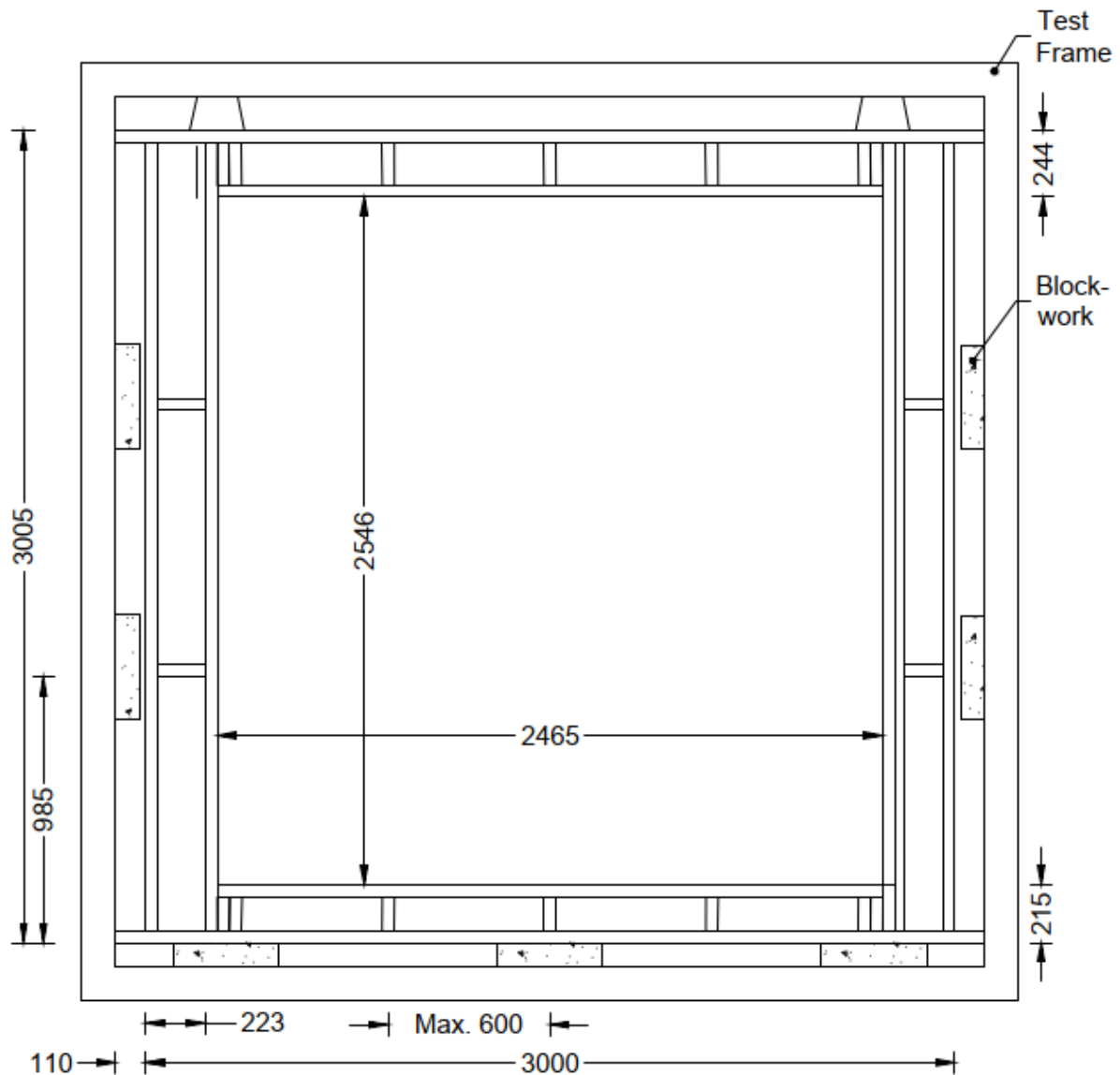

Figure 1 Elevation view of the timber frame

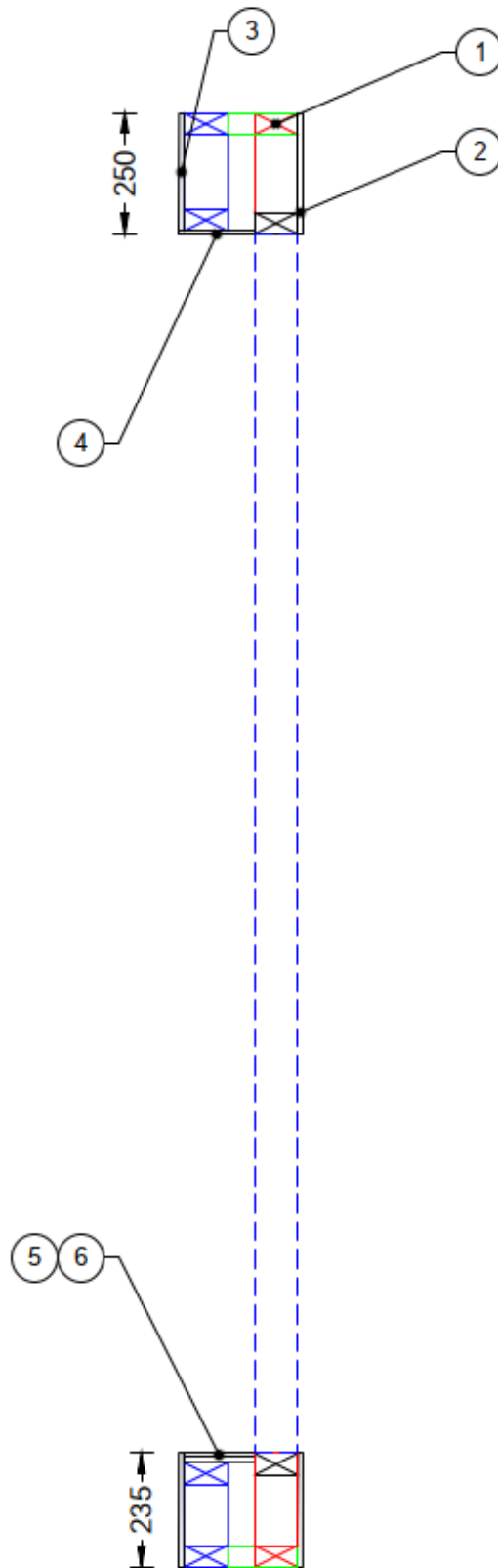

Figure 2 Cross-section of the wall

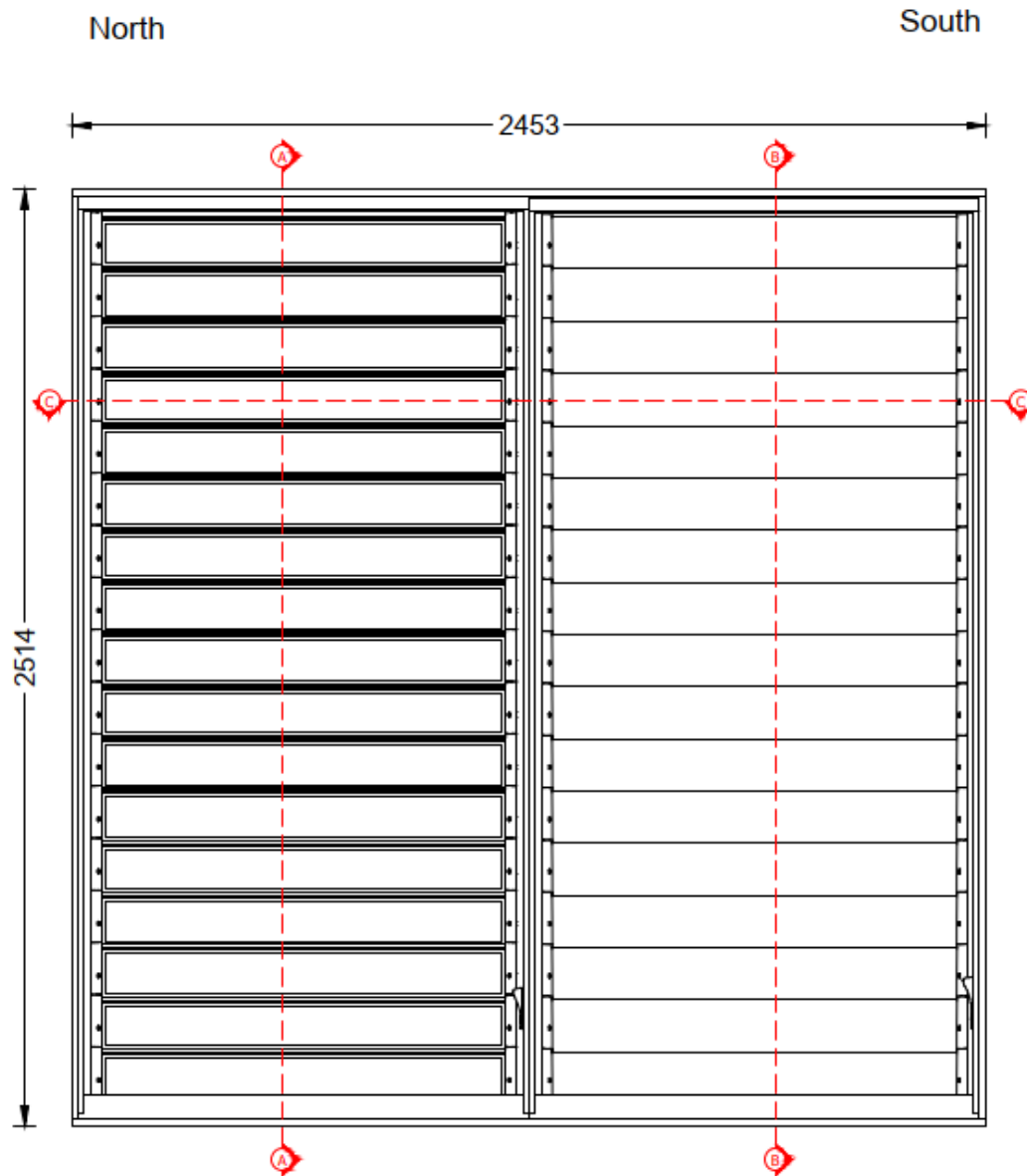

Figure 3 Elevation view of the test specimen (exposed side)

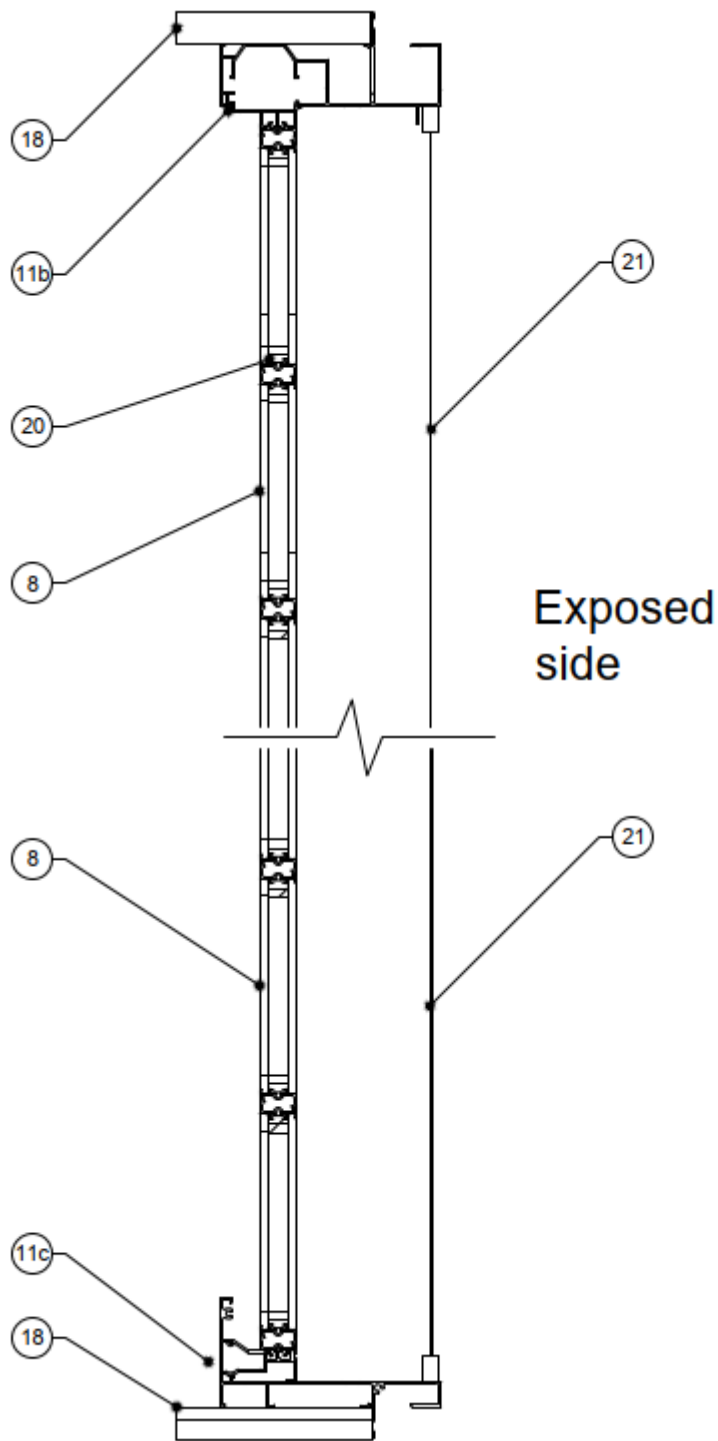

Figure 4 Vertical cross section A-A



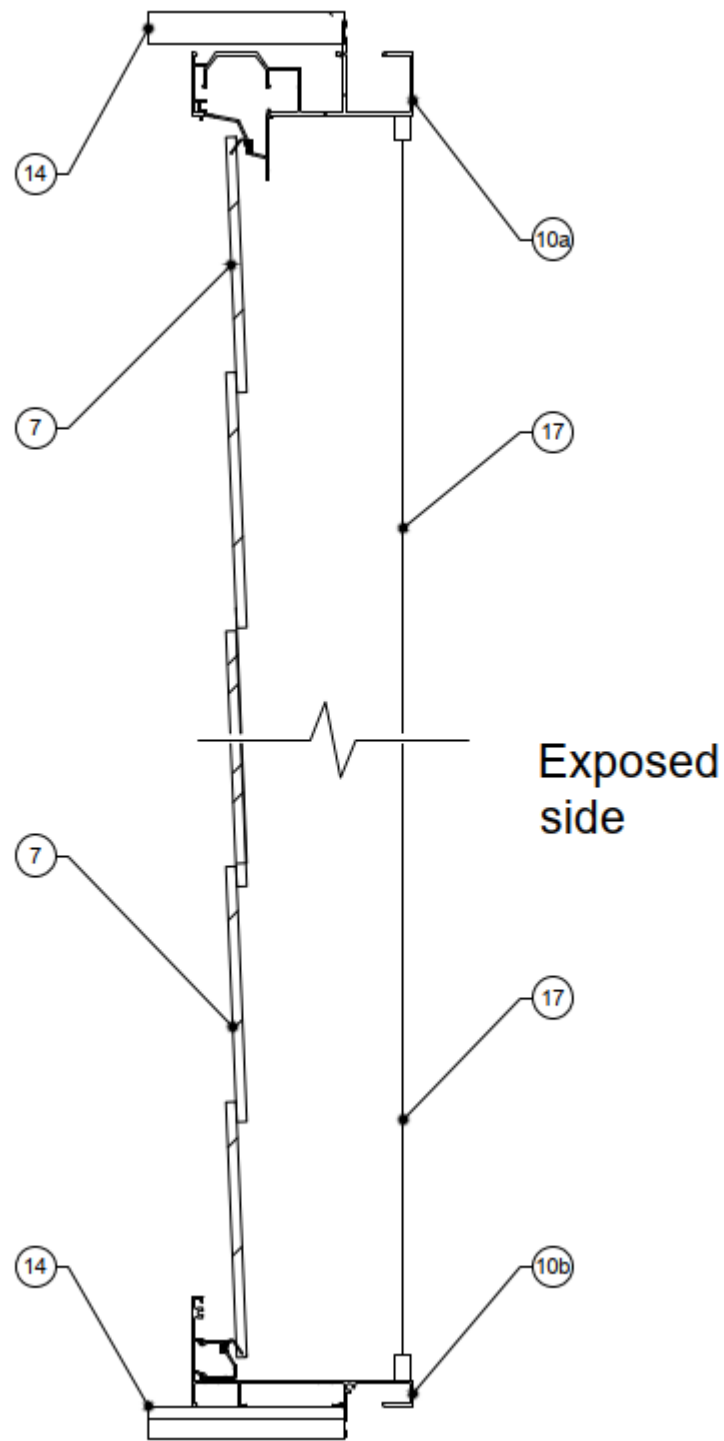

Figure 5 Vertical cross section B-B

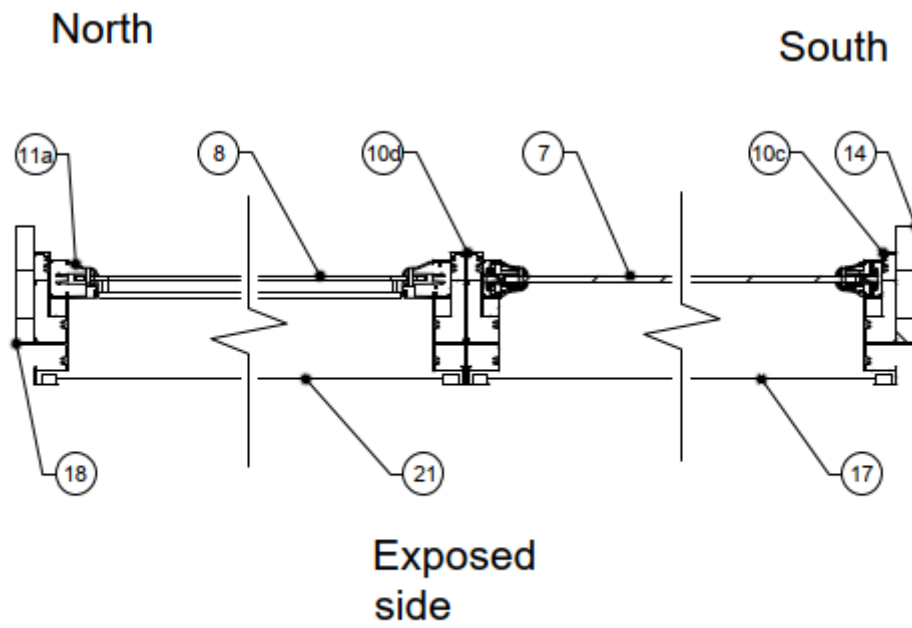

Figure 6 Horizontal cross section C-C

## Appendix B Test observations

Table 9 shows the observations of any significant behaviour of the specimen during the test.

**Table 9 Test observations**

Time		Observation
Min	Sec	
00	00	The simulated bushfire radiant heat test started. Three flaming cribs (class AA) were placed against the test specimen. The ambient temperature of the laboratory was approximately 25 °C.
00	04	The screen shielding the specimen from the radiant heat was removed and the test specimen was exposed to the radiant heat profile for BAL 40, as specified in AS 1530.8.1:2018.
00	42	The security screens were both bending towards the radiant heat panel.
01	14	Smoke was emitting from the exposed side of both security screens, between the mesh and the screen frame.
10	00	The screen was re-positioned in front of the furnace shielding the specimen from the radiant heat and exposure to the radiant heat profile of BAL 40 was stopped. Monitoring of the test specimen against the performance criteria outlined in AS 1530.8.1:2018 continued.
60	00	No further changes to the specimen. Test was stopped in accordance with the procedure outlined in AS 1530.8.1:2018.

## Appendix C Direct field of application

**Note:** The text, figures and tables in this appendix have been taken from AS 1530.8.1:2018.

### C.1 General

The results of the fire test contained in the test report are directly applicable, without reference to the testing authority for a technical opinion, to constructions where a decrease in any linear dimension of the individual panes of glazing is made and/or variations of less than 15° are made to the angle of the tested inclination

**Note:** Glazing inclined at an angle of 18° or less should be evaluated in accordance with clause 18 of AS 1530.8.1:2018.

### C.2 Screens or shutters

Where the specimen is tested in accordance with clause 16.4 of AS 1530.8.1:2018, the results are generally applicable to the screens or shutters that vary as follows:

- The screens or shutters may decrease in size and the overlap of the screen over the opening may increase.
- The screens or shutters may be rebated, fitted or face fitted to the wall, provided the gap between the window and the shutter or screen does not decrease from that tested.

## Appendix D Instrumentation locations



**Note:**

- Black dot shows heat flux gauge location.
- Green dots show deflection locations.

**Figure 7 Heat flux gauge and deflection locations (unexposed side shown)**



**Note:**

- Red dots show thermocouple locations.

**Figure 8 Thermocouple locations (unexposed side shown)**



**Note:**

- Northern crib located at the north jamb.
- Southern crib located at the south jamb.
- Centre crib located at the sill adjacent to the centre coupler.
- Blue dots show internal thermocouple locations.
- Black dots show heat flux gauge locations.
- Orange dots show crib locations.

**Figure 9 Instrumentation locations (exposed side shown)**

The instrumentation was positioned in accordance with the requirements of [standard section] of AS 1530.8.1:2018 – as summarised in Table 10 and Table 11.

**Table 10 Thermocouple locations**

Location	T/C #	Description
Eave	011	Internal surface of the eave above the south crib.
	012	Internal surface of the eave above the centre of the south louvre system
	013	Internal surface of the eave above the centre crib.
	014	Internal surface of the eave above the centre of the north louvre system
	015	Internal surface of the eave above the north crib.
Frame coupler	016	On the north face of the centre coupler, at mid-height and 15 mm from the security screen
	017	On the south face of the centre coupler, at mid-height and mid-depth of the coupler.

**Table 11 Deflection locations**

Location	Ref	Description
Framing	HS	Mid-height of the south jamb
	HC	Mid-height of the centre coupler

**Table 12 Heat flux gauge locations**

Location	Ref	Description
Wall	HFG 1	Located at the mid-height of the specimen at 250 mm from the southern edge, on the exposed face.
Glazing	HFG 2	Located at the centre of the specimen, 365 mm behind the glazing on the unexposed face.
	HFG 3.	Located at the centre of the specimen, 250 mm in front of the glazing on the exposed face. The heat flux gauge was put into position after 20 minutes.



## Appendix E Test data

### E.1 Heat flux measurements

Before the test, the heat flux emitted by the radiant panel was measured at the centre and quarter points. The results shown in Figure 10 were taken at a distance of 3 m away from the exposed face.

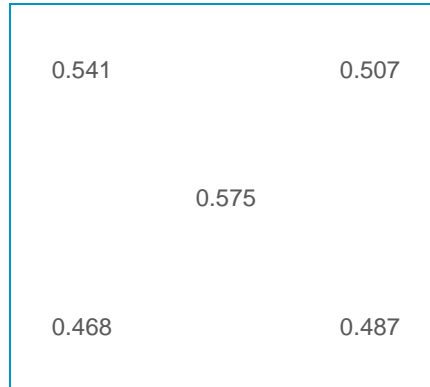

Figure 10 Heat flux emitted by the radiant panel

The average of the irradiance received at each of the quarter points was 87% of that at the central point and satisfied the minimum requirements of clause 13.3 of AS 1530.8.1:2018.

### E.2 Measure of heat flux received

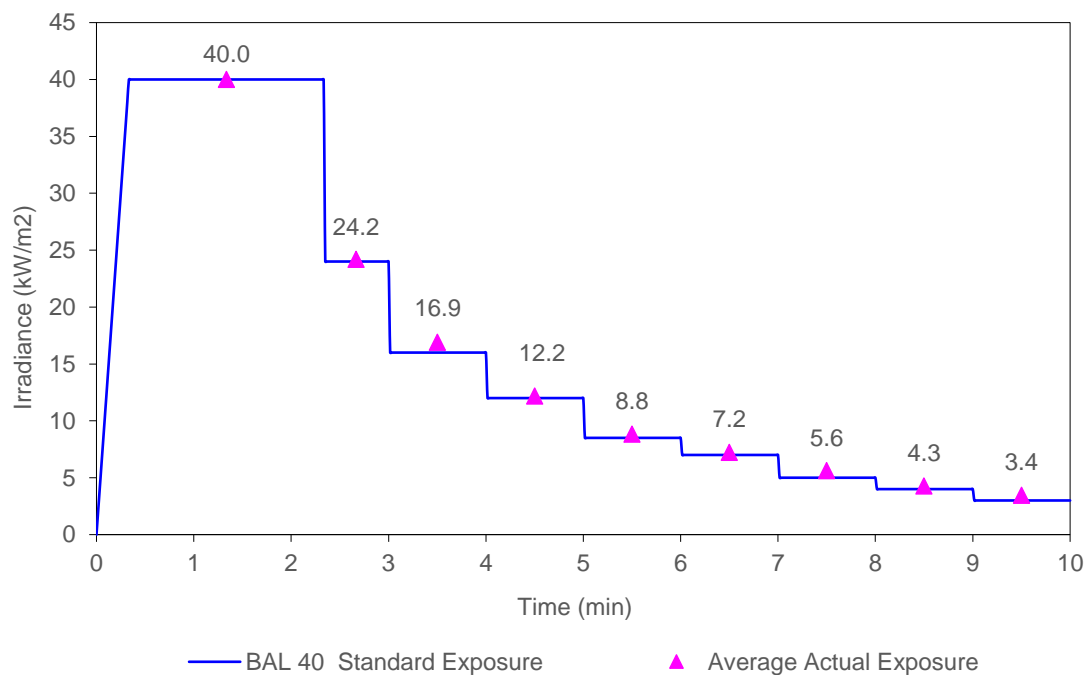

Figure 11 Averaged irradiance levels during the test to the glazing

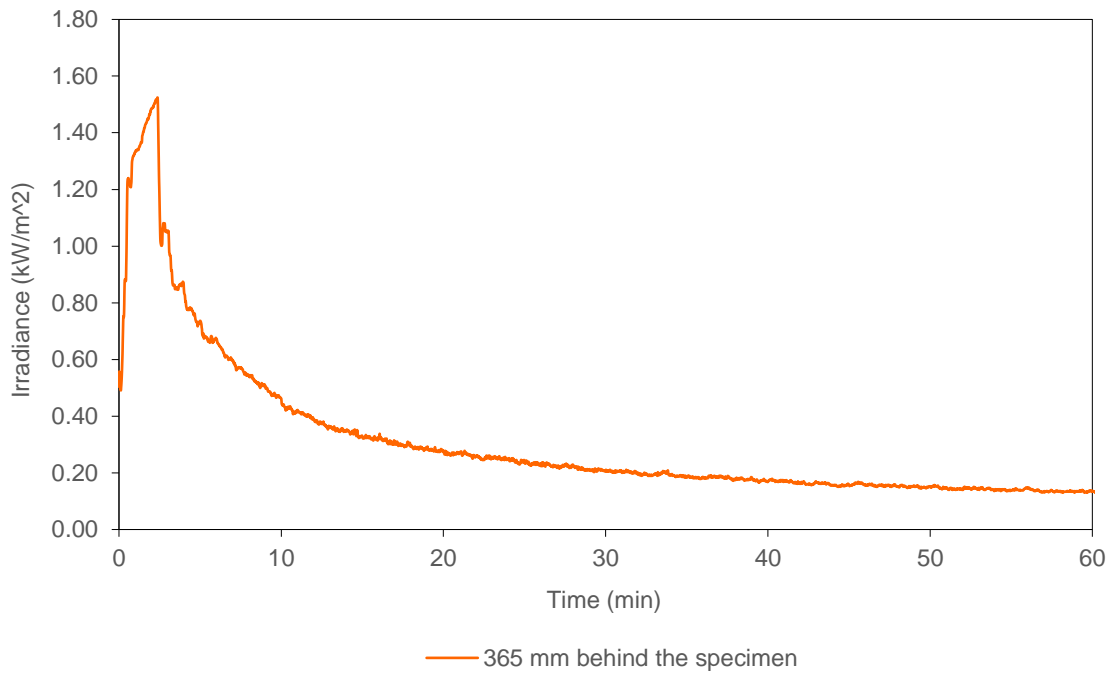

Figure 12 Radiant heat flux received 365 mm behind the specimen

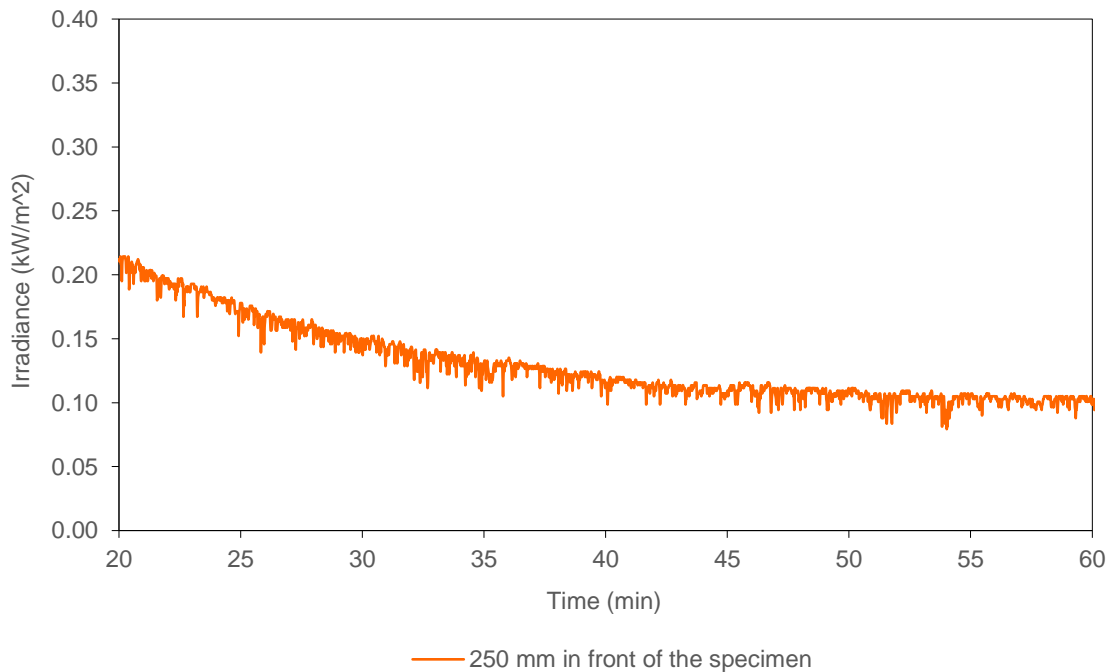

Figure 13 Radiant heat flux received 250 mm in front of the specimen

Less than 21 kW/m<sup>2</sup> heat flux radiation was received by the heat flux gauge positioned centrally to the front of the specimen and 250 mm from the glazing during the time period of 20 to 60 minutes of the test period.

### E.3 Specimen temperatures

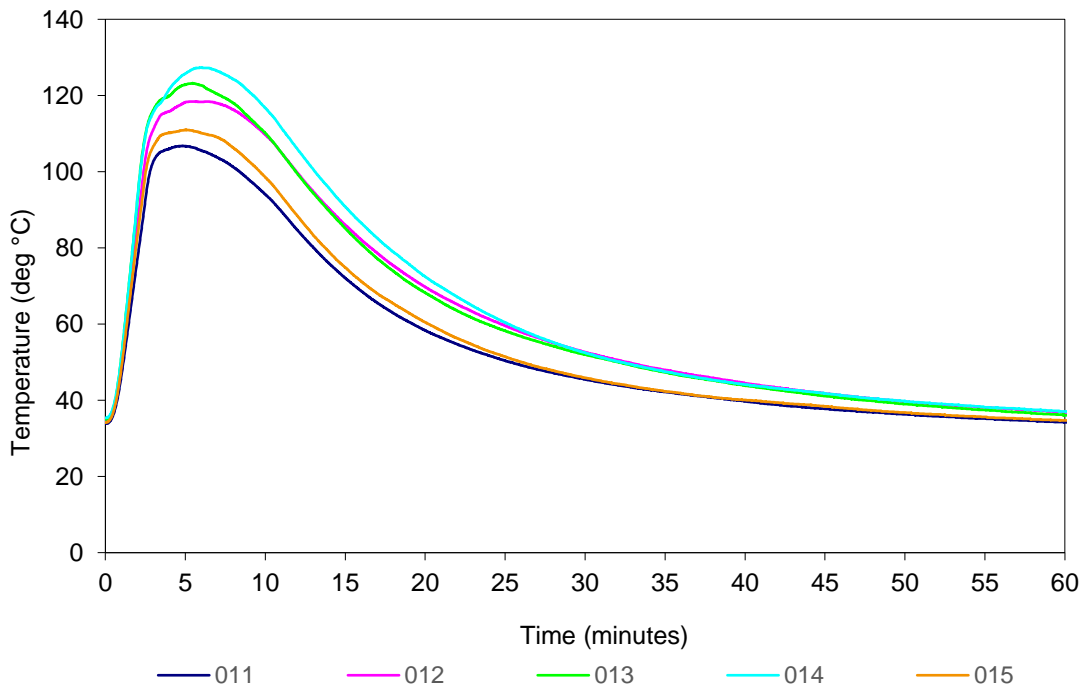

Figure 14 Eave – temperature vs time

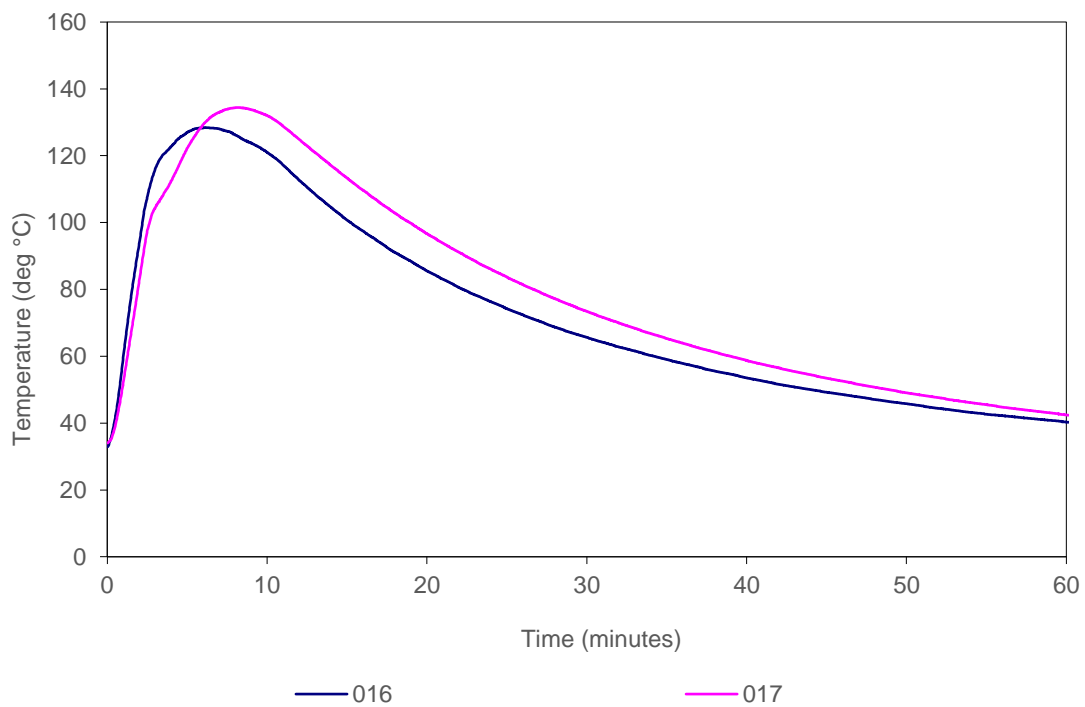

Figure 15 Centre coupler – temperature vs time

**Table 13 Test specimen temperatures**

Location	T/C #	Description <sup>1</sup>	Temp (°C) at t (minutes)					Limit <sup>2</sup> (minutes)
			t=0	t=10	t=20	t=30	t=60	
Eave	011	Internal surface of the eave above the south crib.	34	94	58	46	34	-
	012	Internal surface of the eave above the centre of the south louvre system	35	110	70	53	37	-
	013	Internal surface of the eave above the centre crib.	35	110	68	52	36	-
	014	Internal surface of the eave above the centre of the north louvre system	35	117	72	53	37	-
	015	Internal surface of the eave above the north crib.	34	99	61	46	35	-
Frame coupler	016	On the north face of the centre coupler.	33	121	86	66	40	N/A
	017	On the south face of the centre coupler.	34	132	97	73	43	N/A

- Note:**
- <sup>1</sup> Refer to Table 10 for locations of thermocouples as only a generic description is included in the table.
  - <sup>2</sup> Limit time is the time to the nearest whole minute, rounded down to the nearest minute, at which the temperature recorded by any internal thermocouple does not reach 300 °C, or the average of the internal quarter point thermocouple measured temperatures do not reach 250 °C
  - <sup>3</sup> Under Limit column indicates the temperature limit was not exceeded during the test period or up until the time of integrity failure if a failure occurred.

## E.4 Specimen deflections

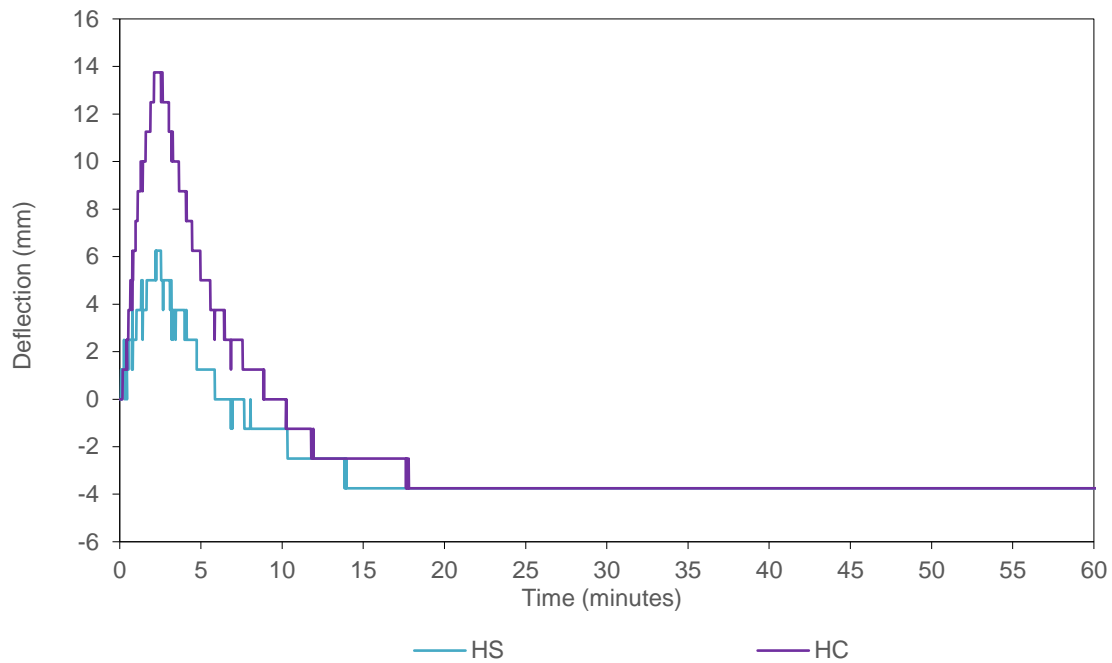

**Note:**

- Positive measurements show movement of the test specimen towards the radiant heat panel.
- Negative measurements show movement of the test specimen away from the radiant heat panel.

**Figure 16** Deflection of the test specimen vs time – horizontal deflection

## Appendix F Photographs



Figure 17 Unexposed face of the specimen before the start of the test



Figure 18 Exposed face of the specimen before the start of the test

South



North

Figure 19 Unexposed face of the specimen at the end of the test

North



South

Figure 20 Exposed face of the specimen at the end of the test

# warringtonfire

Proud to be part of  element



Warringtonfire Australia Pty Ltd  
ABN 81 050 241 524

#### Perth

Unit 22, 22 Railway Road  
Subiaco WA 6008  
Australia  
T: +61 8 9382 3844

#### Canberra

Unit 10, 71 Leichhardt Street  
Kingston ACT 2604  
Australia  
T: +61 2 6260 8488

#### Sydney

Suite 802, Level 8, 383 Kent Street  
Sydney NSW 2000  
Australia  
T: +61 2 9211 4333

#### Brisbane

Suite 6, Level 12, 133 Mary Street  
Brisbane QLD 4000  
Australia  
T: +61 7 3238 1700

#### Melbourne – NATA accredited laboratory

409-411 Hammond Road  
Dandenong South VIC 3175  
Australia  
T: +61 3 9767 1000

#### General conditions of use

The data, methodologies, calculations and results documented in this report specifically relate to the tested specimen/s and must not be used for any other purpose. This report may only be reproduced in full. Extracts or abridgements must not be published without permission from Warringtonfire.

All work and services carried out by Warringtonfire are subject to, and conducted in accordance with, our standard terms and conditions. These are available on request or at <https://www.element.com/terms/terms-and-conditions>.